



Istruzioni di montaggio Instructions d'assemblage  
Assembling instructions Aufbau Anweisungen  
Instrucciones de montaje

**IMPORTANTE! CONSERVARE PER  
RIFERIMENTO FUTURO:  
LEGGERE ATTENTAMENTE.**

IMPORTANT! KEEP FOR FUTURE  
REFERENCE: READ CAREFULLY.

**IMPORTANT! À CONSERVER POUR  
CONSULTATION ULTÉRIEURE:  
À LIRE ATTENTIVEMENT.**

WICHTIG! BITTE AUFMERKSAM  
DURCHLESEN UND GUT  
AUFBEWAHREN.

**IMPORTANTE! GUARDAR PARA  
FUTURAS CONSULTAS:  
LEER ATENTAMENTE.**



- **Tempo approssimativo assemblaggio 20 minuti, 2 persone per assemblaggio.**
- Approximate assembly time 20 minutes, 2 people for assembly.
- **Temps de montage approximatif 20 minutes, 2 personnes.**
- Ungefähre Aufbauzeit 20 Minuten, 2 Personen pro Aufbau.
- **Tiempo aproximado para montaje 20 minutos, 2 personas por ensamblaje.**



Valable uniquement pour la France  
Alleen geldig voor Frankrijk

**I**

Prodotto in plastica

**NON ESPORRE** a + 50°C e - 0°

Usare su una superficie piana.

Pulire con acqua e sapone, **NON USARE SOLVENTI****Carico Massimo della seduta: 110 kg**

Le eventuali leggere differenze di colore tra i vari componenti sono dovute alla natura ecologica della materia prima che usiamo

**ARTICOLO AD USO DOMESTICO E COLLETTIVITÀ**

Prodotto, testato e certificato a Norma Europea EN-581

**D**

Kunststoffprodukt

**KEINER TEMPERATUR AUSSETZEN**, die über 50°C oder unter -0°C liegt

Auf einer ebenen Oberfläche verwenden.

Nur mit Wasser und Seife reinigen,

**KEINE LÖSUNGSMITTEL VERWENDEN.****Maximale Sitzbelastung: 110 kg**

Leichte Farbunterschiede zwischen den einzelnen Komponenten sind auf den ökologischen Charakter der verwendeten Rohstoffe zurückzuführen.

**ARTIKEL FÜR DEN PRIVAT UND OBJEKTBEREICH**

Hergestellt, getestet und zertifiziert gemäss

Europäischer Norm EN-581

**GB**

Plastic product

**DO NOT EXPOSE** to + 50°C and - 0°

Use on a level surface.

Clean using soap and water, **DO NOT USE SOLVENTS****Maximum Sitting load: 110 kg**

Any slight differences in color between components are due to the ecological nature of the raw material we use

**ARTICLE FOR DOMESTIC USE AND COMMUNITY USE**

Produced, tested and certified in compliance with

European Standard EN-581

**E**

Producto de plástico

**NO EXPONGA** a + 50°C y - 0°

Use sobre una superficie plana.

Limpie con agua y jabón, **NO USE SOLVENTES****Carga máxima del asiento: 110 kg**

Las ligeras diferencias de color entre los distintos componentes se deben a la naturaleza ecológica de la materia prima que utilizamos.

**ARTÍCULO PARA USO DOMÉSTICO Y COLECTIVIDADES**

Producto, probado y certificado según la norma europea en-581

**F**

Produit en plastique

**NE PAS EXPOSER** à + 50°C et à - 0°C

A utiliser sur un support plan.

Nettoyer avec eau et savon, **NE PAS UTILISER DE SOLVANTS****Charge maximale sur le siège : 110 kg**

Les légères différences de couleur entre les différents composants sont dues à la nature écologique de la matière première que nous utilisons.

**ARTICLE À USAGE DOMESTIQUE ET COLLECTIVITE**

Produit, testé et certifié aux Normes Européennes EN-581

**PT**

Produto de plástico

**NÃO EXPOR** a + 50°C e - 0°

Usar sobre uma superfície plana.

Limpar com água e sabão, **NÃO USAR SOLVENTES****Carga máxima do assento: 110 kg**

Quaisquer pequenas diferenças de cor entre os vários componentes se devem à natureza ecológica da matéria-prima que usamos.

**ARTIGO PARA USO DOMÉSTICO E CONTRACT**

Produto, testado e certificado de scordo com a norma europeia en-

581

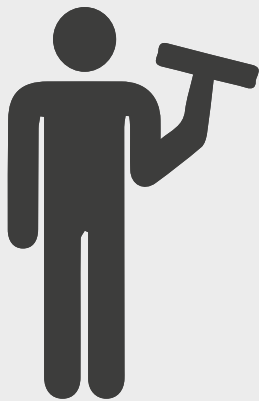

- Pulire con acqua e detersivo liquido o cremoso evitando prodotti abrasivi. Risciacquare bene e asciugare.
- Clean with water and liquid or creamy detergent avoiding abrasive products. Rinse well and dry.
- Nettoyer avec de l'eau et un détergent liquide ou crémeux en évitant les produits abrasifs. Bien rincer et sécher.
- Mit Wasser und flüssigem oder cremigem Reinigungsmittel reinigen. Scheuermittel vermeiden. Gut abspülen und trocknen.
- Limpiar con agua y detergente líquido o cremoso evitando productos abrasivos. Enjuague bien y seque.
- Limpe com água e detergente líquido ou cremoso evitando produtos abrasivos. Enxágüe bem e arye.

**ATTENZIONE**

Lavare le federe soltanto a mano ed in acqua fredda

**ATTENTION**

Laver les housses à la main et à l'eau froide seulement

**ATTENTION**

Hand wash the covers with cold water only

**ACHTUNG**

Kissenbezüge nur von Hand in kaltem Wasser waschen.

**ATENCIÓN**

Lavar las fundas a mano en agua fría

**ATENÇÃO**

Lavar as capas das almofadas à mão em água fria

# Elenco Componenti

**COMPONENT LIST**  
LISTE DES COMPOSANTS  
**KOMPONENTENLISTE**  
LISTA DE COMPONENTES  
**LISTA DE COMPONENTES**



A x4



E x1



B x3

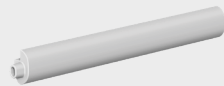

F x10



C x3



G x2



H x4

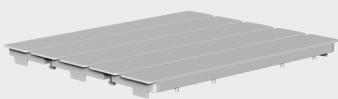

D x5



I x18

# Montaggio Tavolino

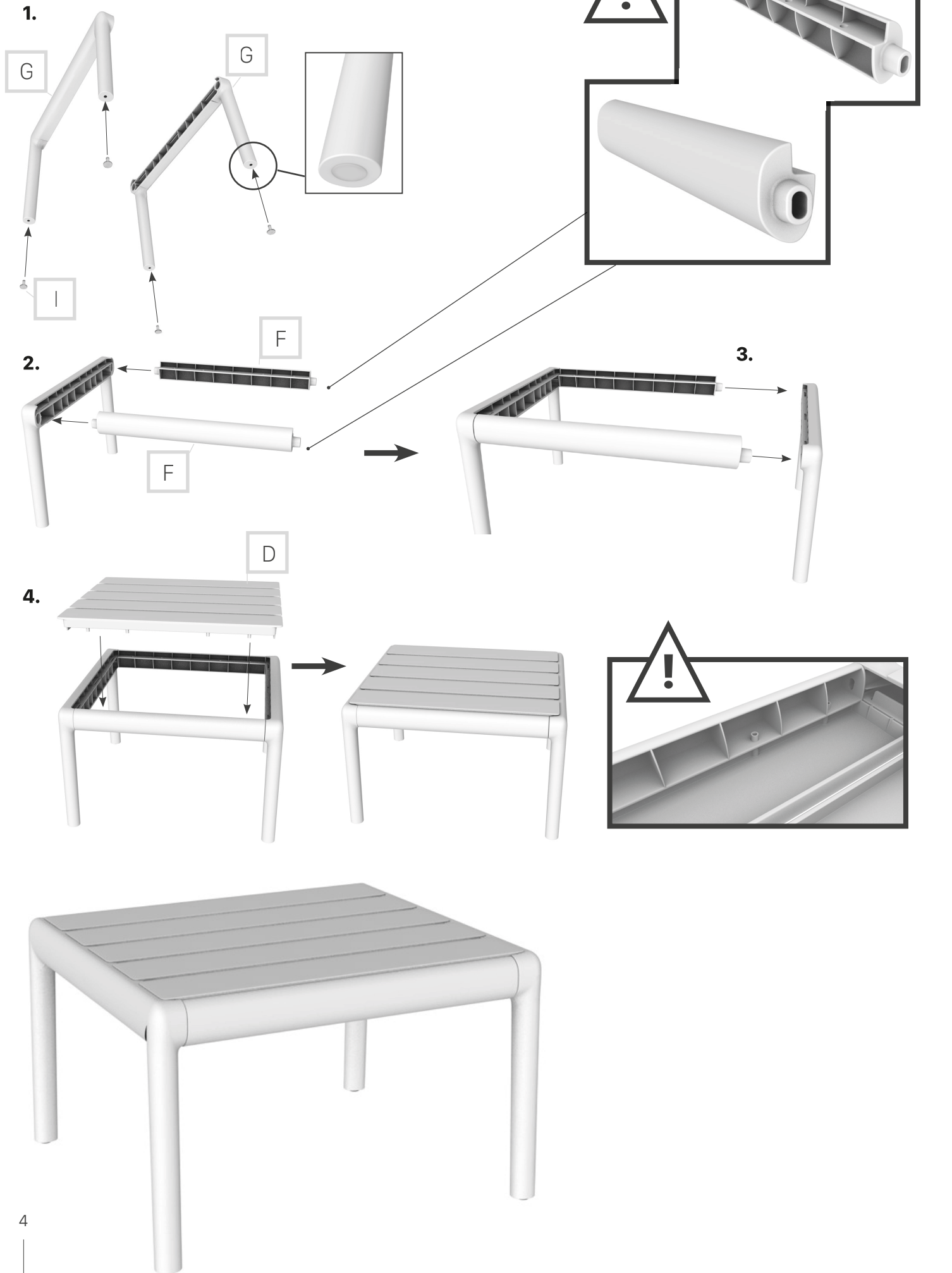

# Montaggio Poltrona

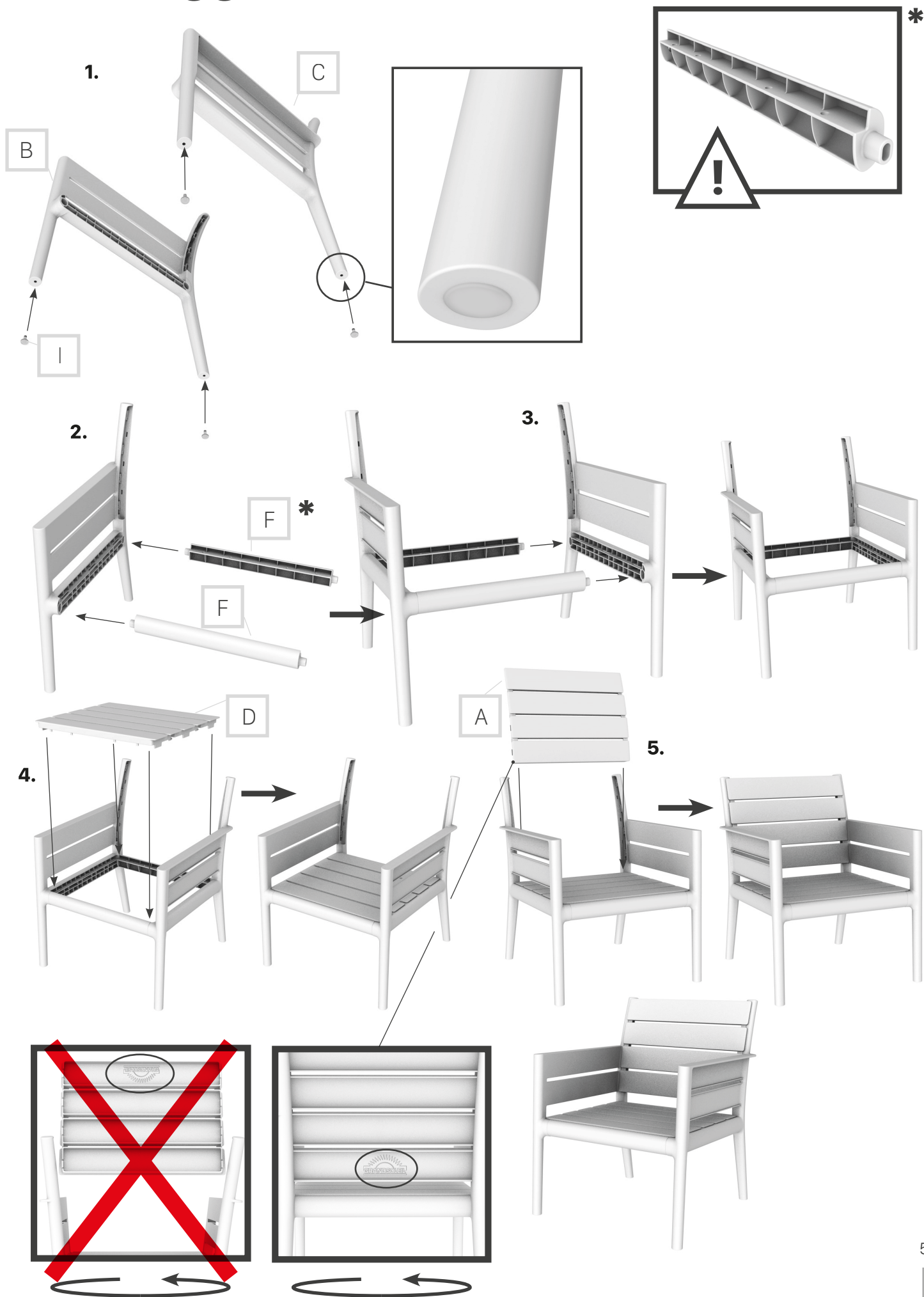



# Montaggio Divano

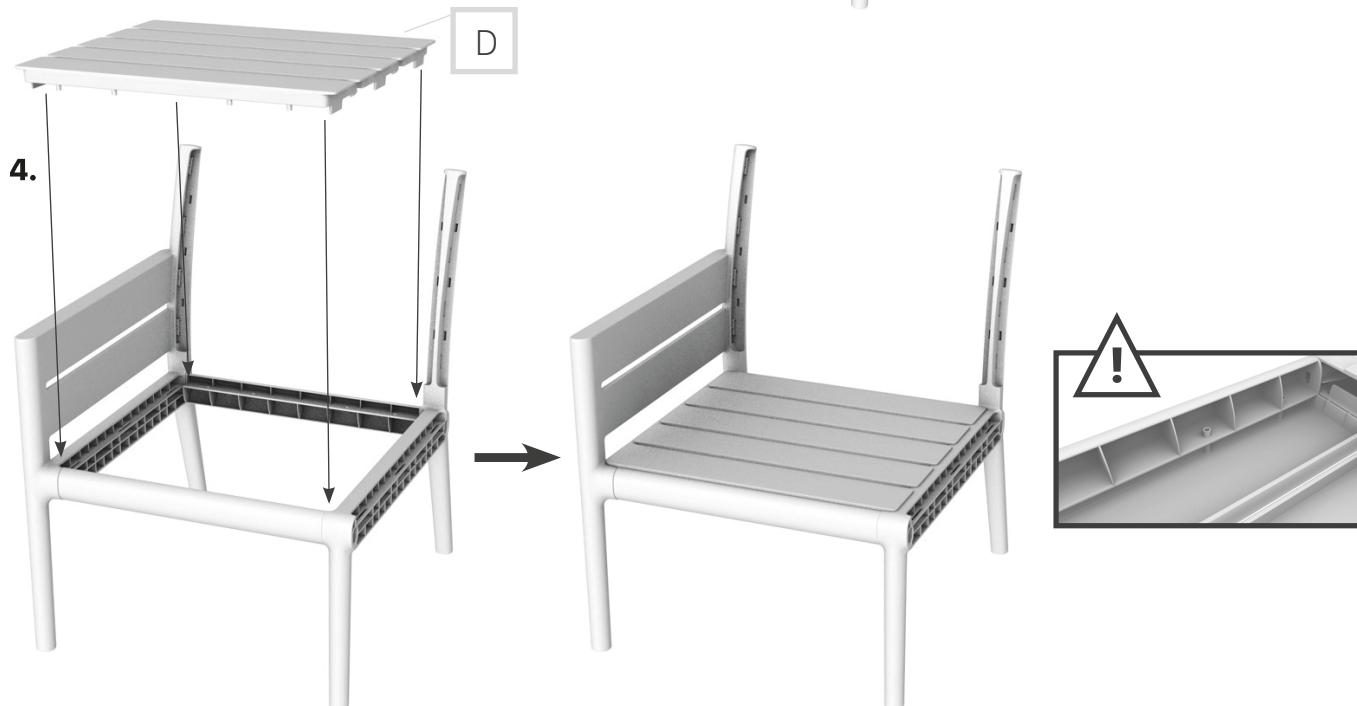
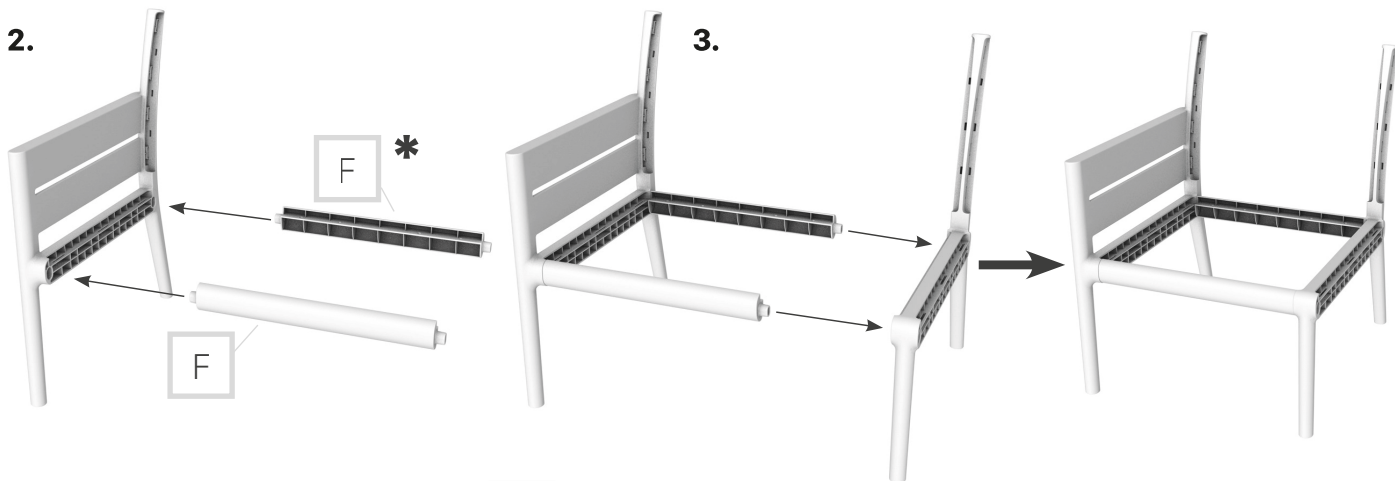
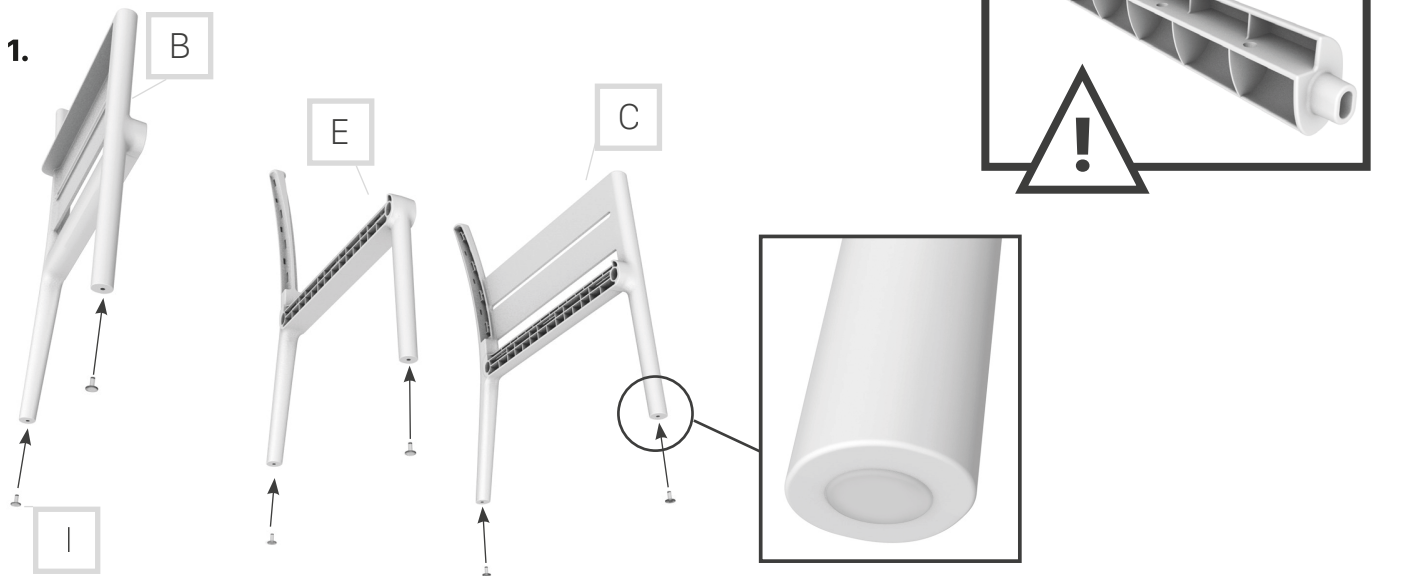

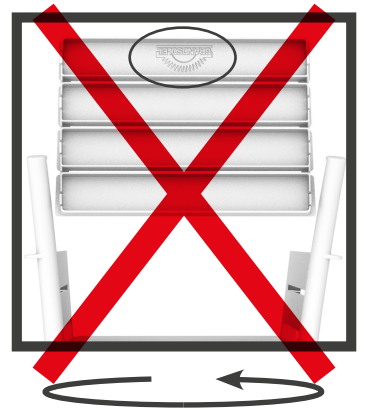
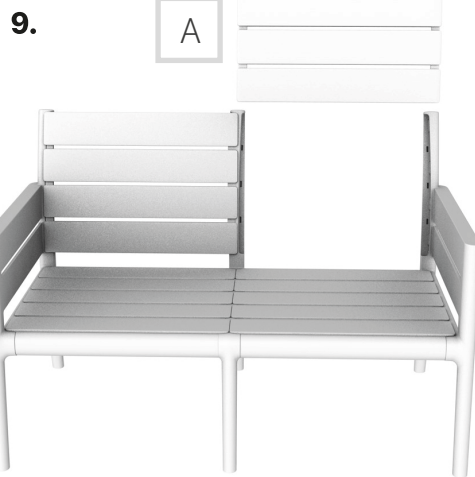
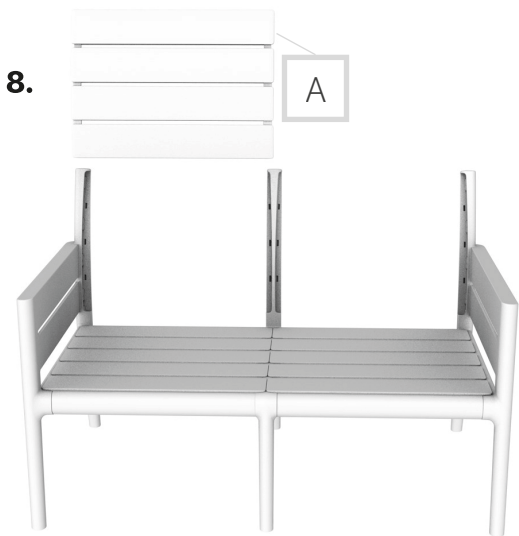
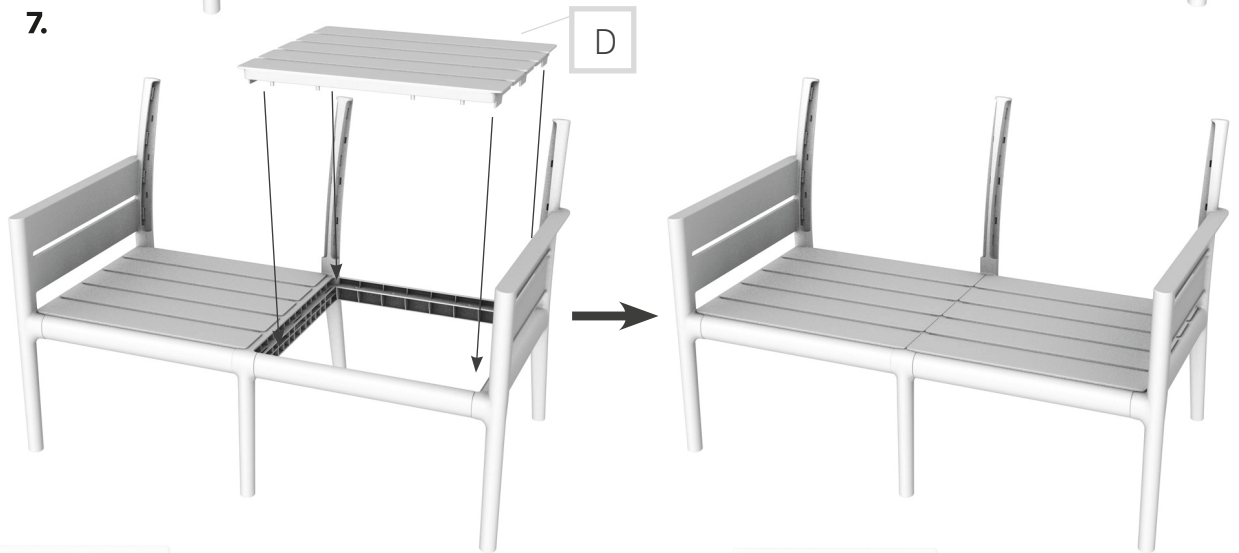
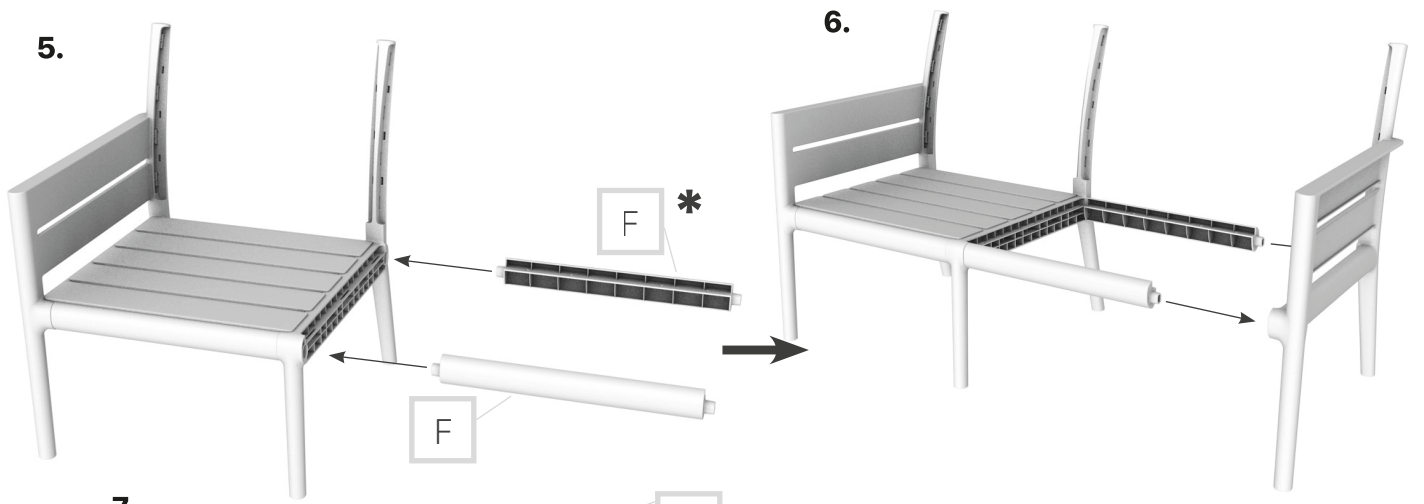



#### **STABILIMENTI E UFFICI COMMERCIALI**

IGAP S.p.A. | Via Garibaldi 244  
46013 Canneto S/Oglio (MN) | Italy  
Tel: +39.0376.7172200 | +39.0376.723705  
Fax: +39.0376.7172290  
Email: [grandsoleil@grandsoleilspa.it](mailto:grandsoleil@grandsoleilspa.it)

#### **SEDE LEGALE E AMMINISTRAZIONE**

IGAP S.p.A. | Via Aldo Moro 1/D  
46019 Cogozzo di Viadana (MN) | Italy  
C.F. e P.IVA: IT 00140560202  
Tel: +39.0375.790294 | Fax: +39.0375.88439