

BROOKLYN 93x90

ISTRUZIONI DI MONTAGGIO

INSTRUCTIONS D'ASSEMBLAGE ASSEMBLING INSTRUCTIONS

AUFBAU ANWEISUNGEN INSTRUÇÕES DE MONTAGE

Prodotto da **IGAP** spa nello stabilimento di: 46013 Canneto S/Oglio (Mantova) Via Garibaldi, 244 • Tel. +39 0376.7172200 • Fax. +39 0376.7172290

- I** IMPORTANTE, CONSERVARE PER UN FUTURO RIFERIMENTO: LEGGERE CON ATTENZIONE.
- GB** IMPORTANT, KEEP FOR FUTURE REFERENCE: READ CAREFULLY.
- F** IMPORTANT : À LIRE ATTENTIVEMENT ET À CONSERVER POUR UNE CONSULTATION ULTÉRIEURE.
- D** WICHTIG! BITTE AUFMERKSAM DURCHLESEN UND FÜR ZUKUNFTIGE REFERENZ AUFBEWAHREN.
- E** IMPORTANTE: CONSERVE EL PRESENTE MANUAL PARA FUTURAS CONSULTAS. LEA ATENTAMENTE ESTAS INSTRUCCIONES.
- P** IMPORTANTE, GUARDAR PARA UMA REFERÊNCIA FUTURA: LER COM ATENÇÃO.

USO ESTERNO - EXTERNAL USE - USAGE EXTERNE - ÄUSSERLICHE ANWENDUNG - USO EXTERNO - USO EXTERNO



- Tempo approssimativo assemblaggio 20 minuti, 1 persona per assemblaggio.
- *Approximate assembly time 20 minutes, 1 people per assembly.*
- Temps de montage approximatif 20 minutes, 1 personne.
- *Ungefähre Aufbauzeit 20 Minuten, 1 Personen pro Aufbau.*
- Tiempo aproximado de ensamblaje 20 minutos, 1 personas por ensamblaje.
- *Tempo aproximado de montagem 20 minutos, 1 pessoas por montagem.*

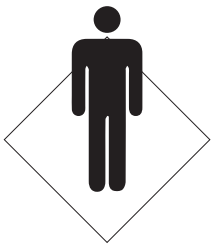

- Spazio necessario per assemblaggio, superficie piana e non abrasiva, pavimento 2m x 2m.
- *Space required for assembly, flat and non abrasive surface, 2m x 2m floor.*
- Espace requis pour le montage, surface plane et non abrasive, plancher 2m x 2m.
- *Platzbedarf für die Montage, flache und nicht abrasive Oberfläche, 2 x 2 m Boden.*
- Montar en el suelo (2x2mts) con una superficie plana y no abrasiva para evitar dañar la mesa.
- *Espaço necessário para montagem, superfície plana e não abrasiva, piso de 2m x 2m.*



- Pulire con acqua e detersivo liquido o cremoso evitando prodotti abrasivi. Risciacquare bene e asciugare.
- *Clean with water and liquid or creamy detergent avoiding abrasive products. Rinse well and dry.*
- Nettoyer avec de l'eau et un détergent liquide ou crémeux en évitant les produits abrasifs. Bien rincer et sécher.
- *Mit Wasser und flüssigem oder cremigem Reinigungsmittel reinigen und Scheuermittel vermeiden. Gut abspülen und trocknen.*
- Limpiar con agua y detergente líquido o cremoso evitando productos abrasivos. Enjuague bien y seque.
- *Limpe com água e detergente líquido ou cremoso evitando produtos abrasivos. Enxaguar bem e secar.*

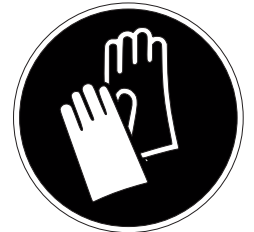

- **Attenzione:** durante il montaggio bisogna indossare i guanti da lavoro.
- **Attention:** during assembly work gloves must be worn.
- **Attention:** pendant le montage, des gants de travail doivent être portés.
- **Achtung:** Während der Montagearbeiten müssen Handschuhe getragen werden.
- **Atención:** durante el montaje se deben llevar guantes de trabajo.
- **Atenção:** durante a montagem deve-se usar luvas de trabalho.

- I** ARTICOLO AD USO COLLETTIVITÀ
- GB** ARTICLE FOR COMMUNITY USE
- F** ARTICLE À USAGE DE LA COLLECTIVITÉ
- D** ARTIKEL FÜR OBJEKTBEREICH
- E** ARTÍCULO PARA COLECTIVIDADES.
- P** ARTIGO PARA USO DA COLECTIVIDADE

- I** Prodotto, testato e certificato a Norma Europea EN-581
- GB** Produced, tested and certified in compliance with European Standard EN-581
- F** Produit testé et certifié aux normes Européennes EN-581
- D** Hergestellt, getestet und zertifiziert gemäß Europäischer Norm EN-581
- E** Producto, probado y certificado según la norma europea en-581
- P** Produto, testado e certificado de acordo com a norma europeia en-581

Art. IS920101



- **Attenzione:** durante il montaggio bisogna indossare i guanti da lavoro.
- **Attention:** during assembly work gloves must be worn.
- **Attention:** pendant le montage, des gants de travail doivent être portés.
- **Achtung:** Während der Montagearbeiten müssen Handschuhe getragen werden.
- **Atención:** durante el montaje se deben llevar guantes de trabajo.
- **Atenção:** durante a montagem deve-se usar luvas de trabalho.

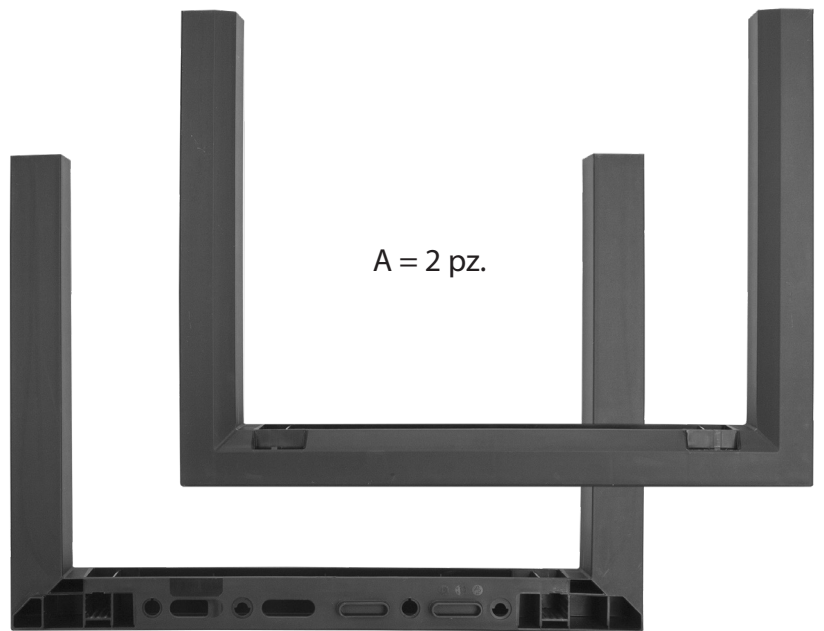

B = 1 pz.

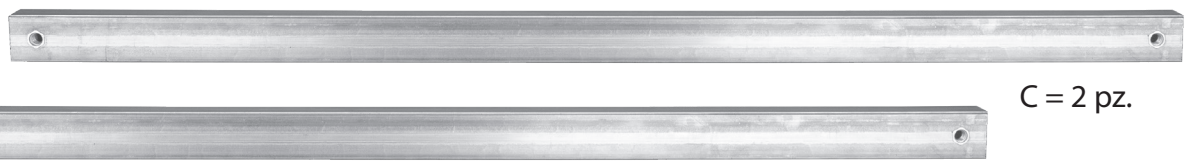

C = 2 pz.

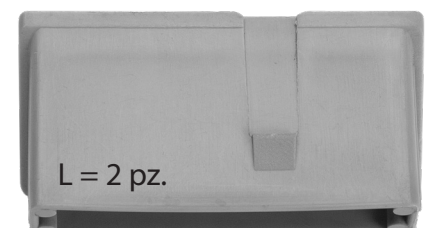
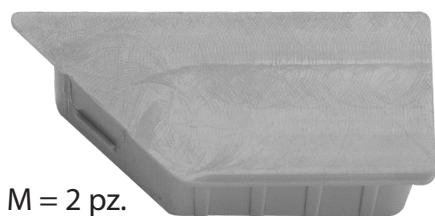
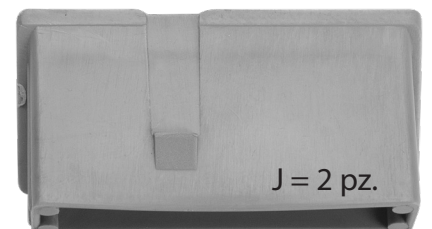
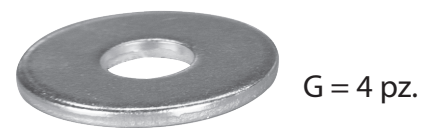
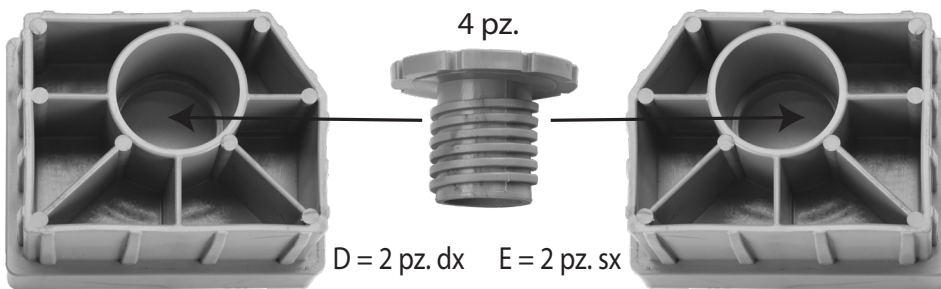

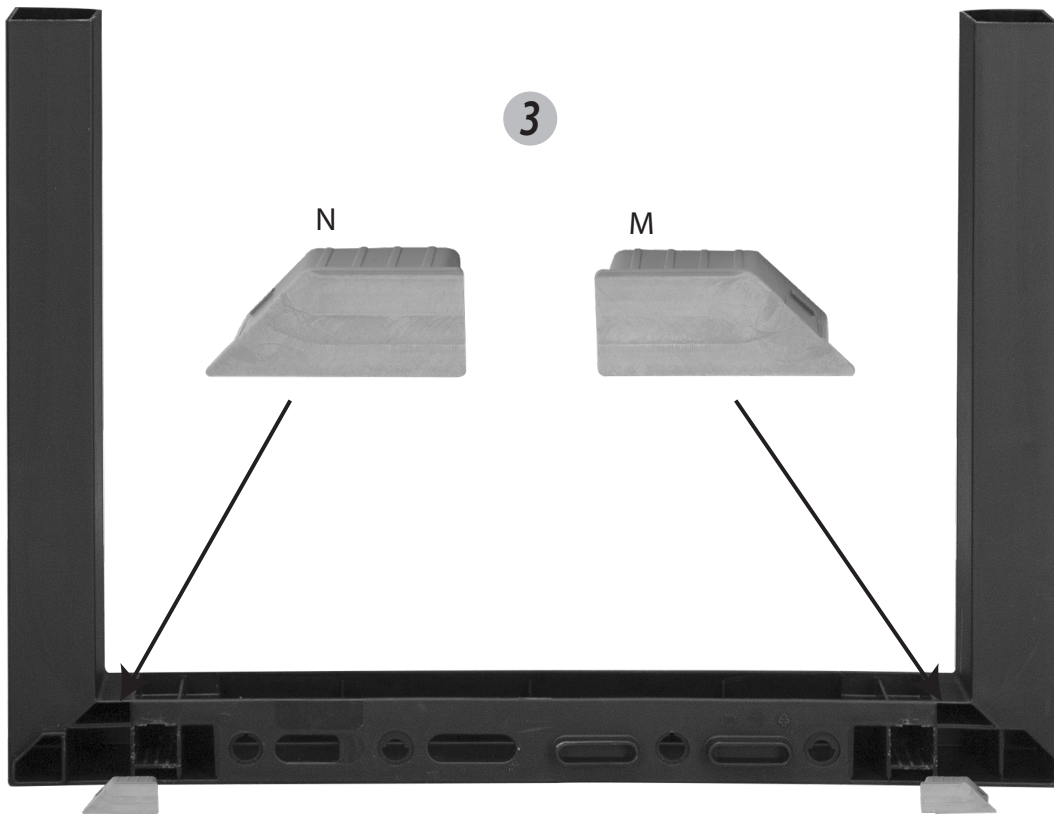
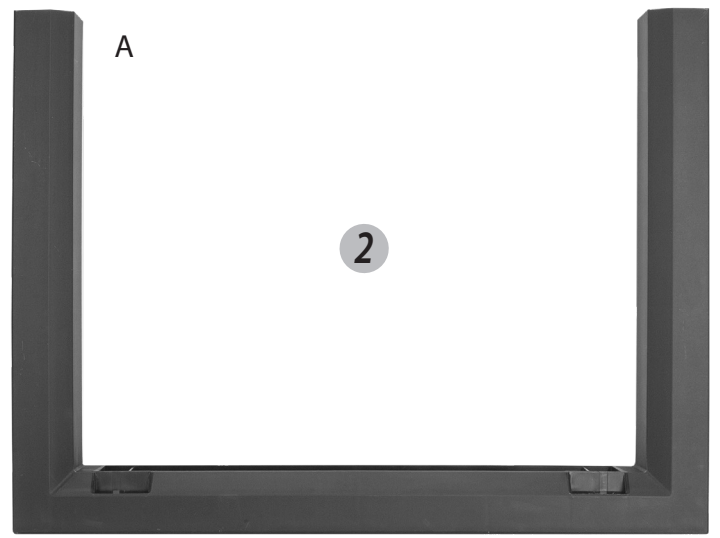
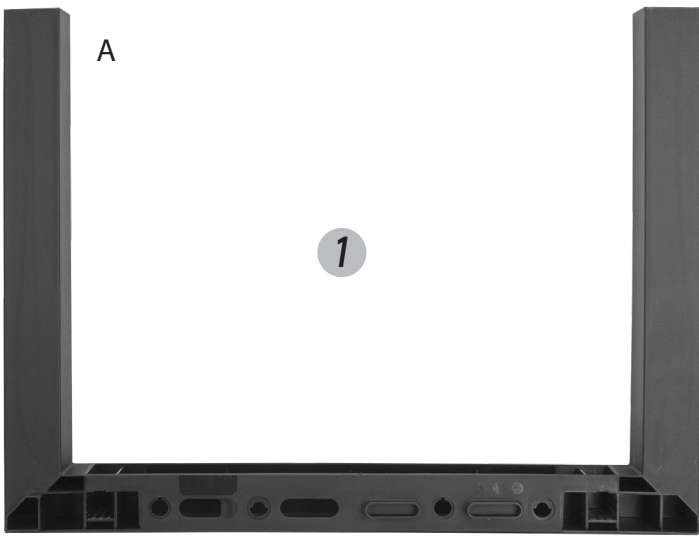

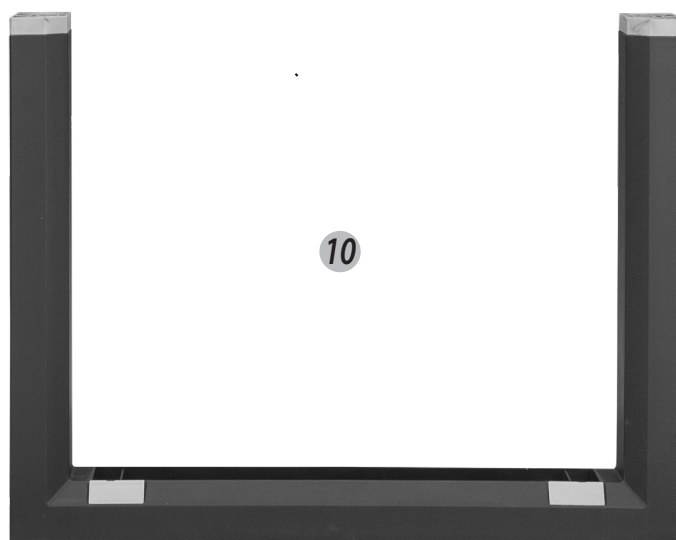
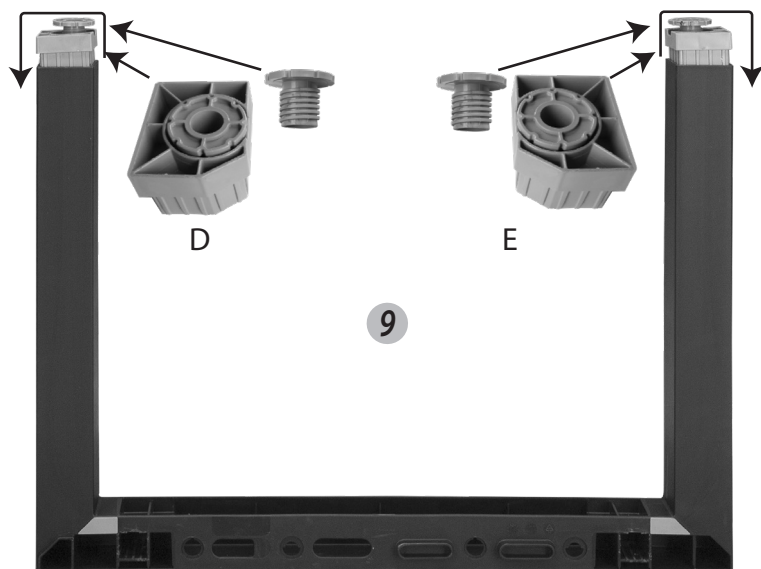
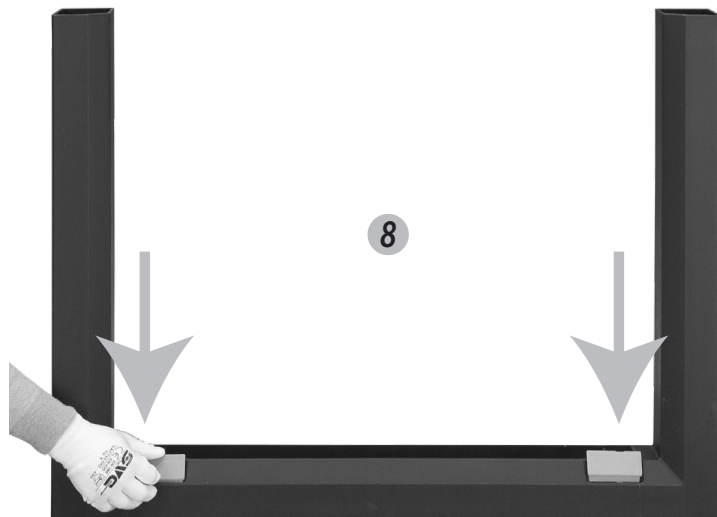
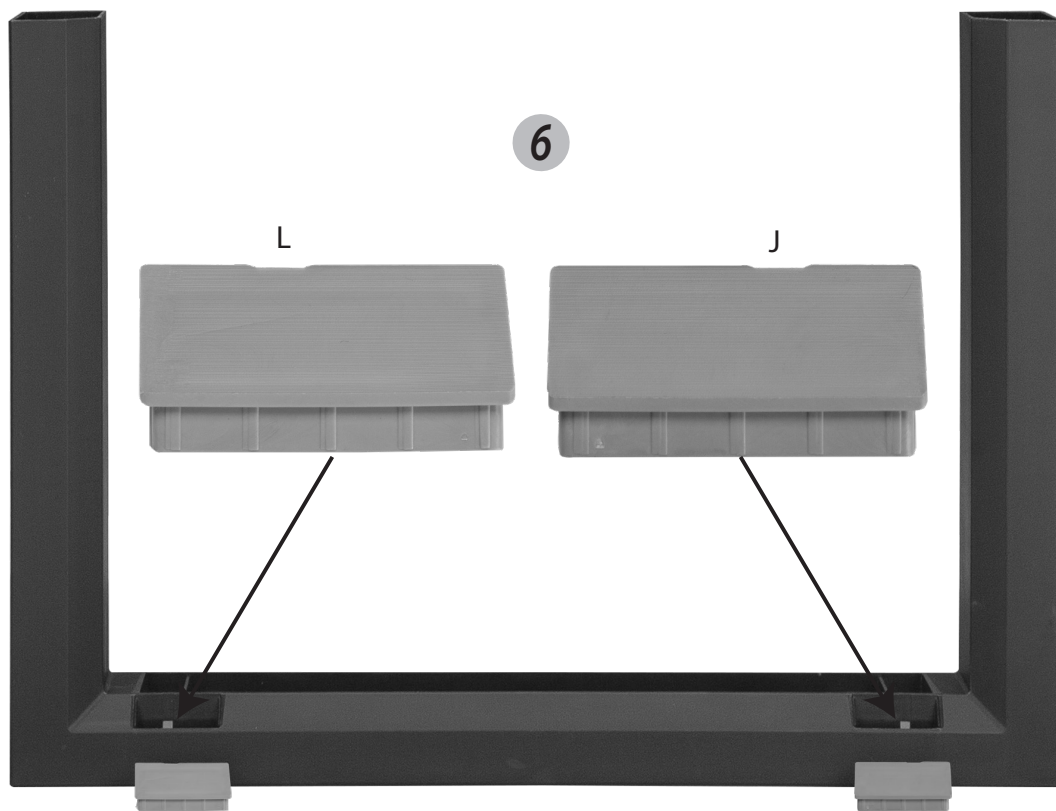

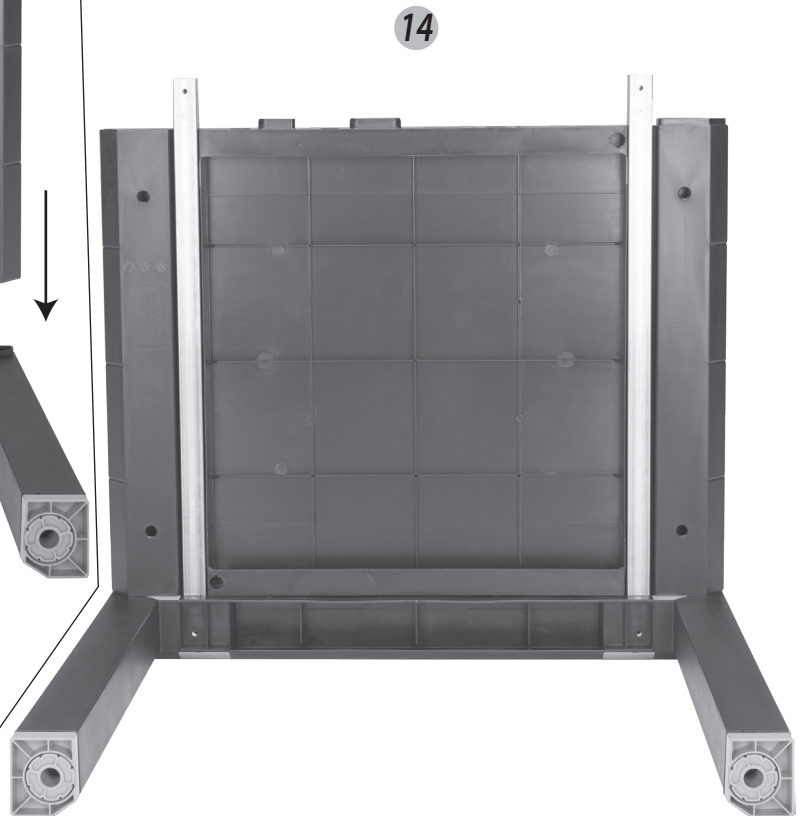
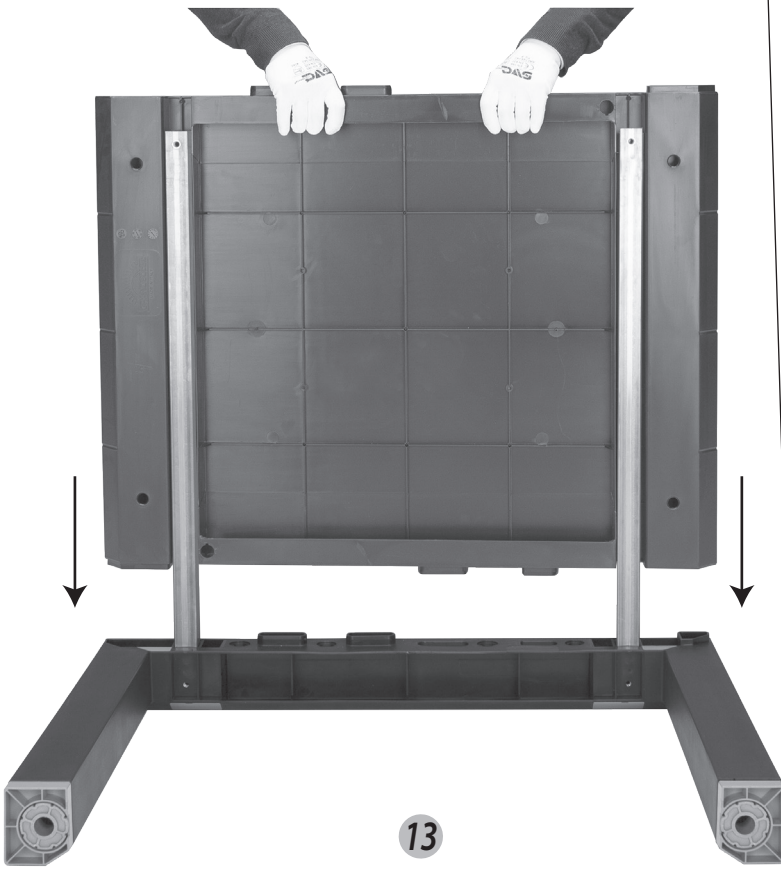
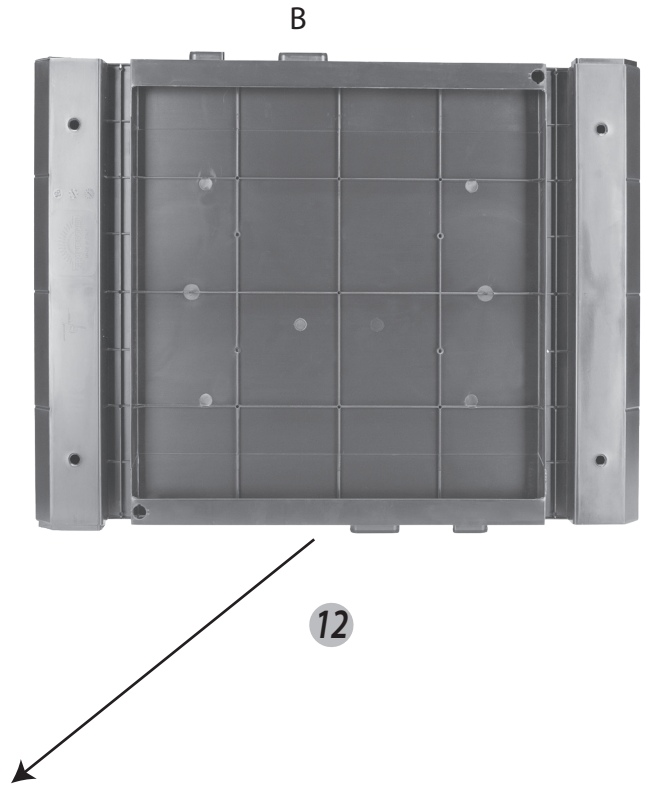

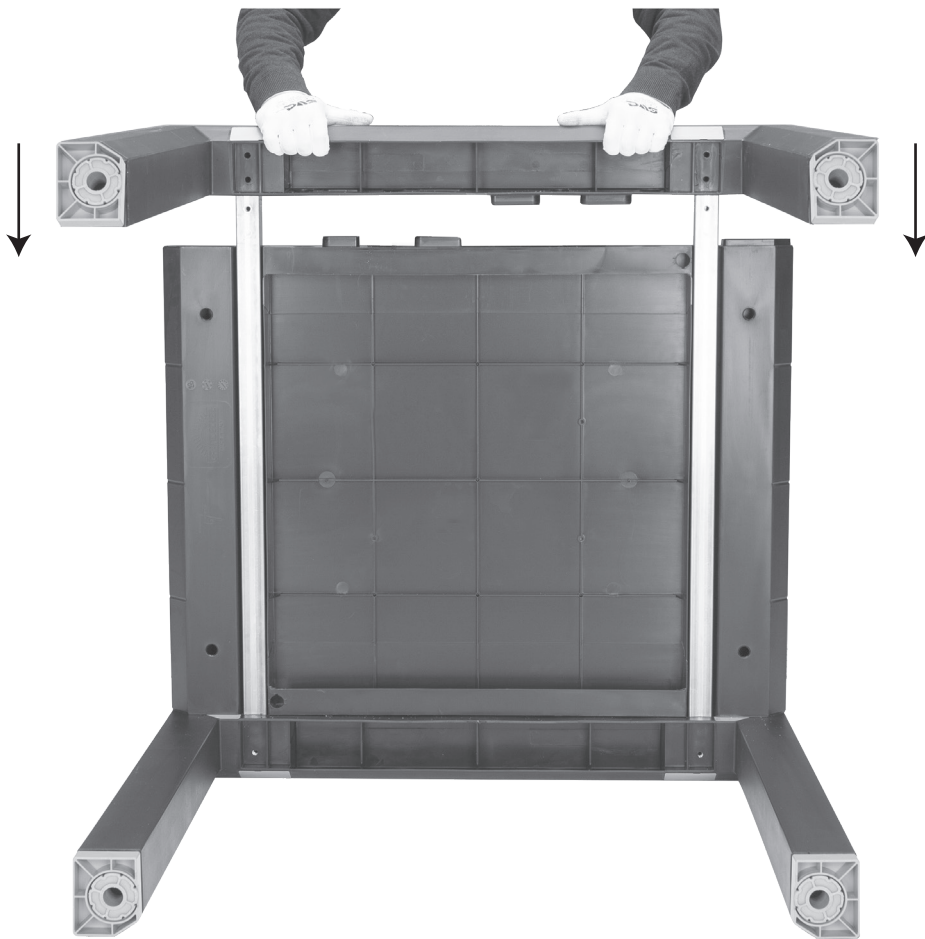

16

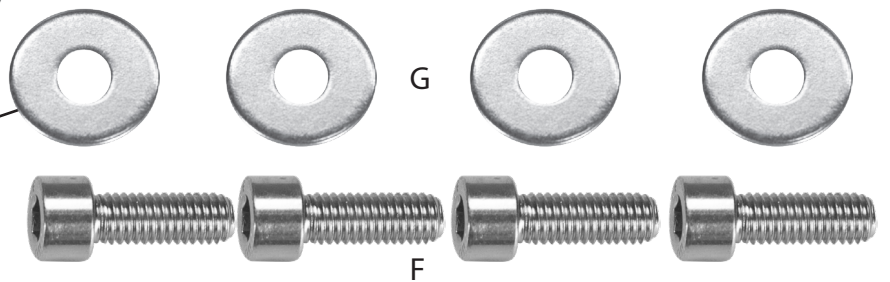
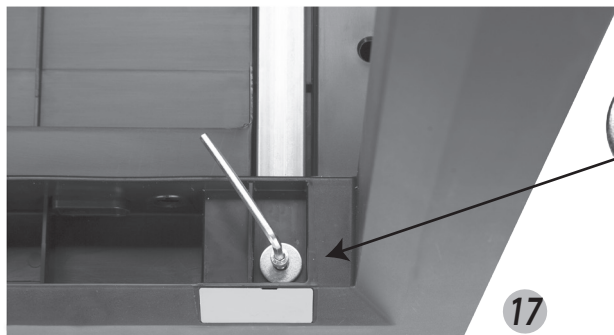
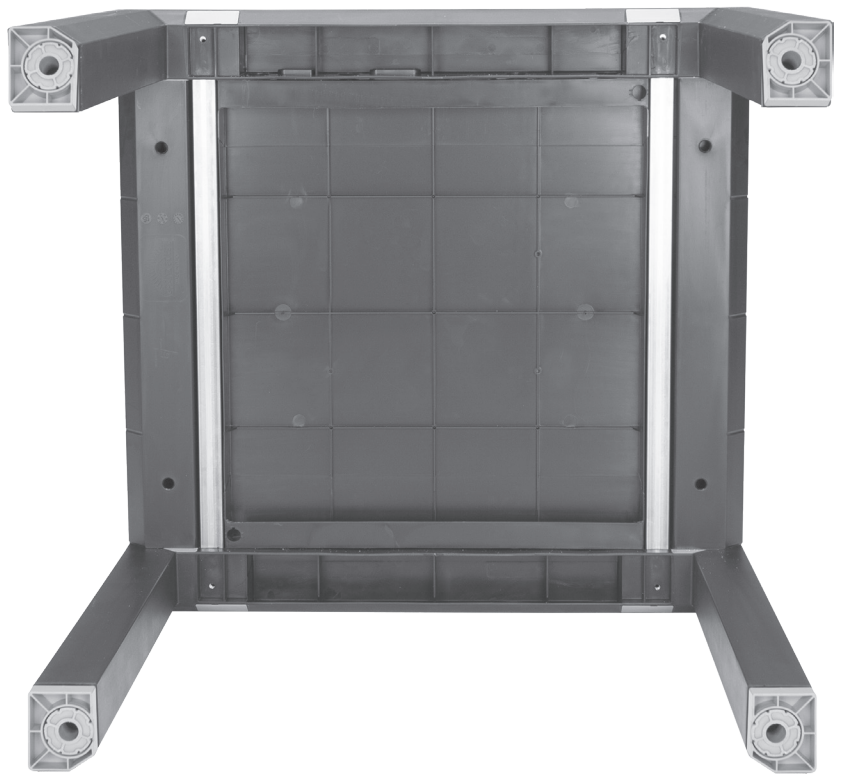



OK

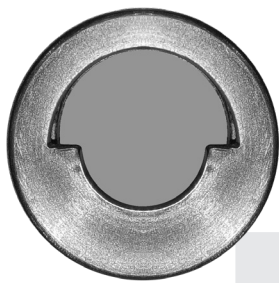

NO

18

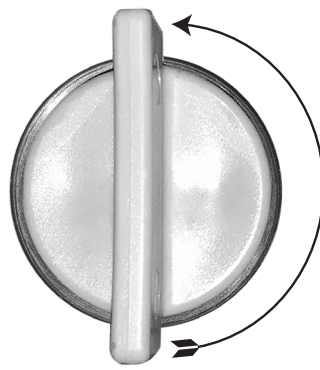
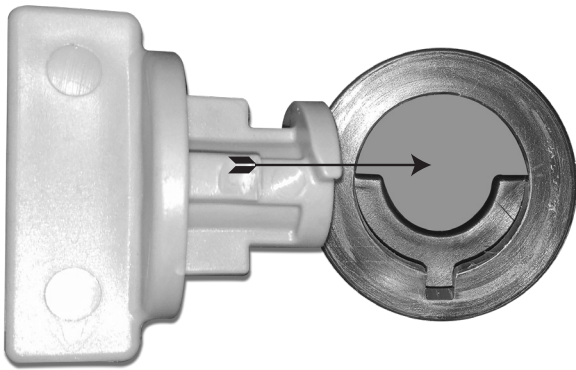
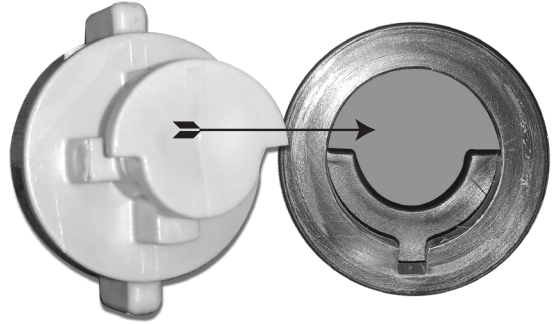

180°

19

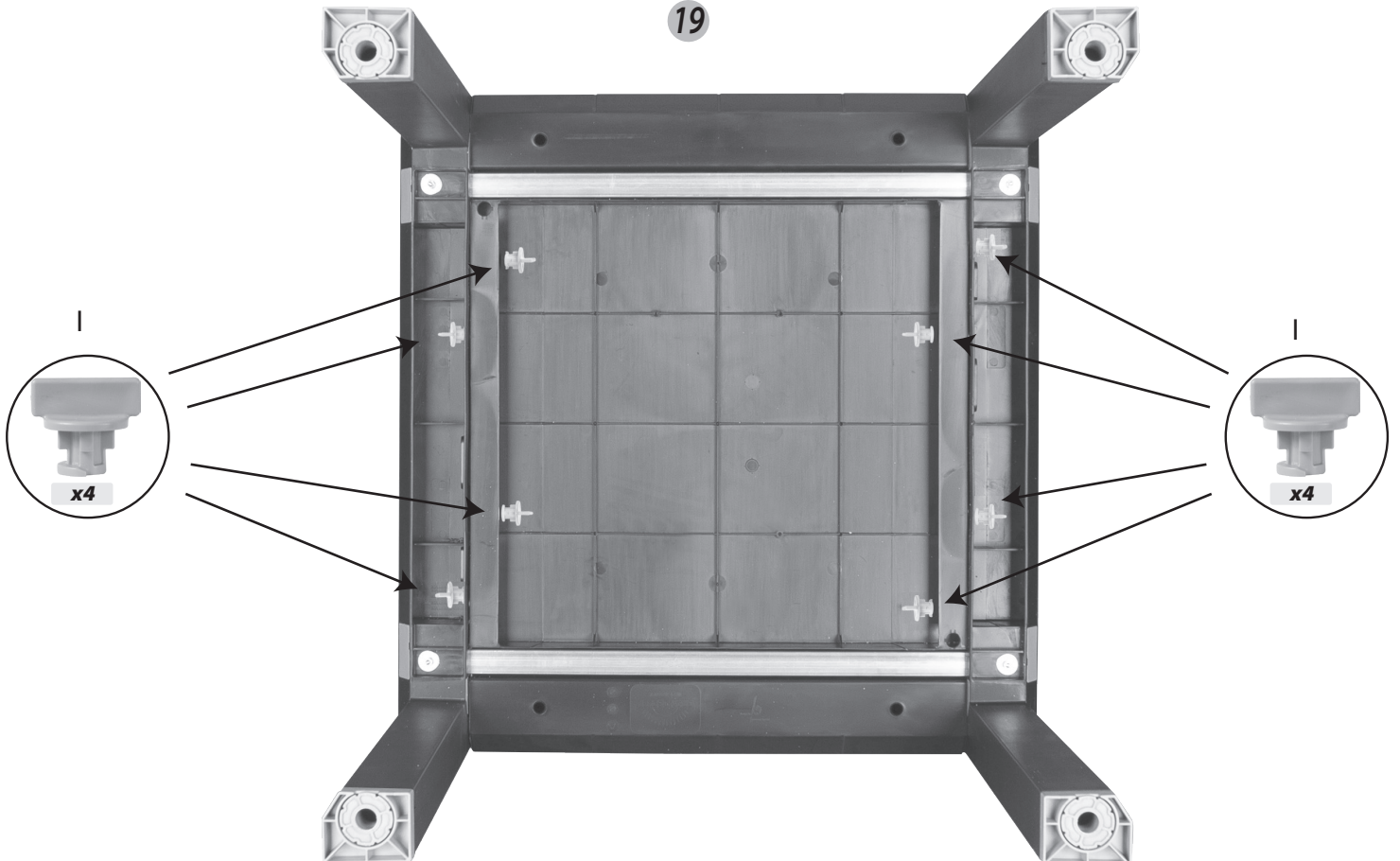

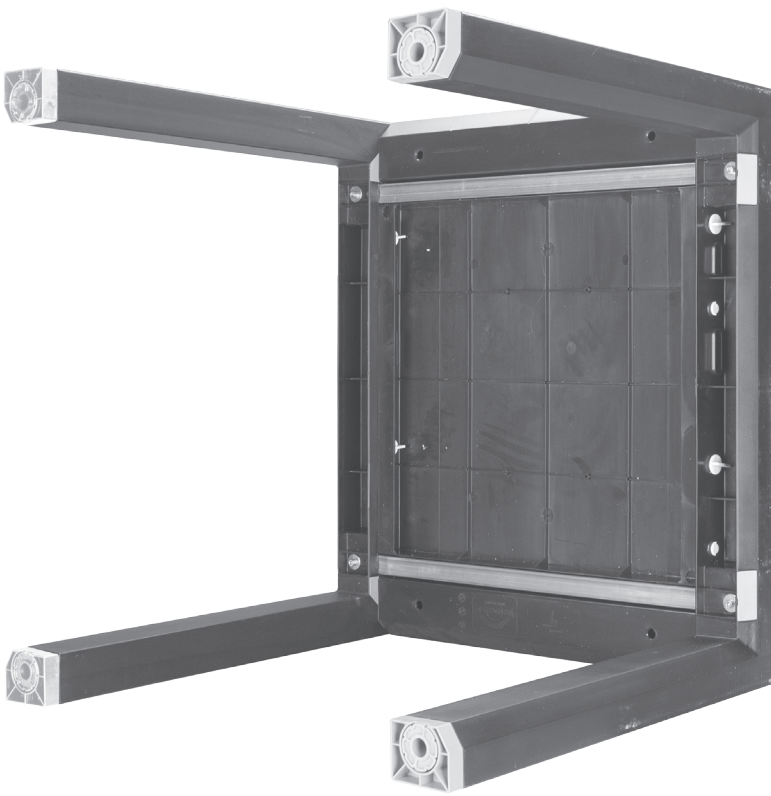

20

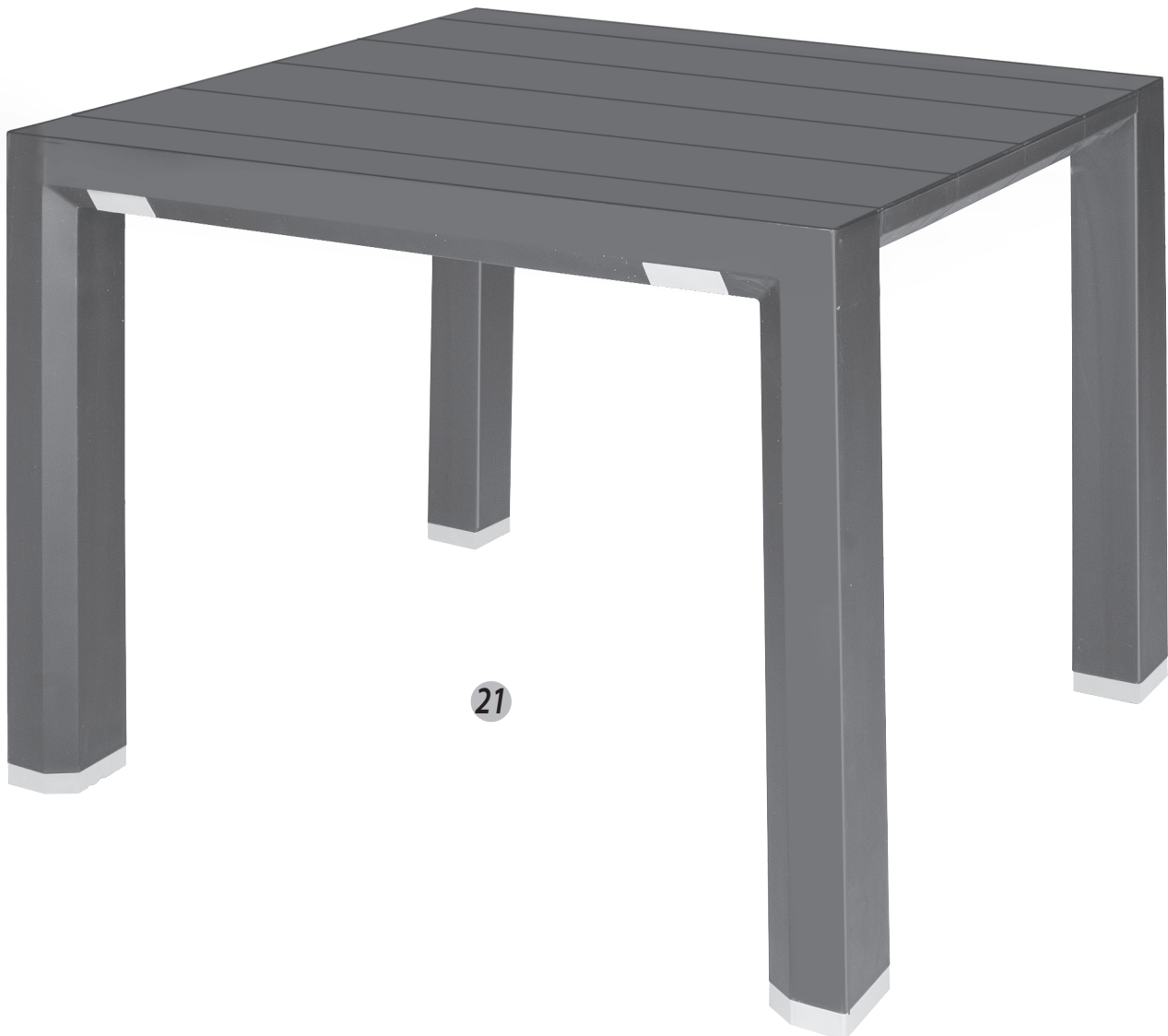
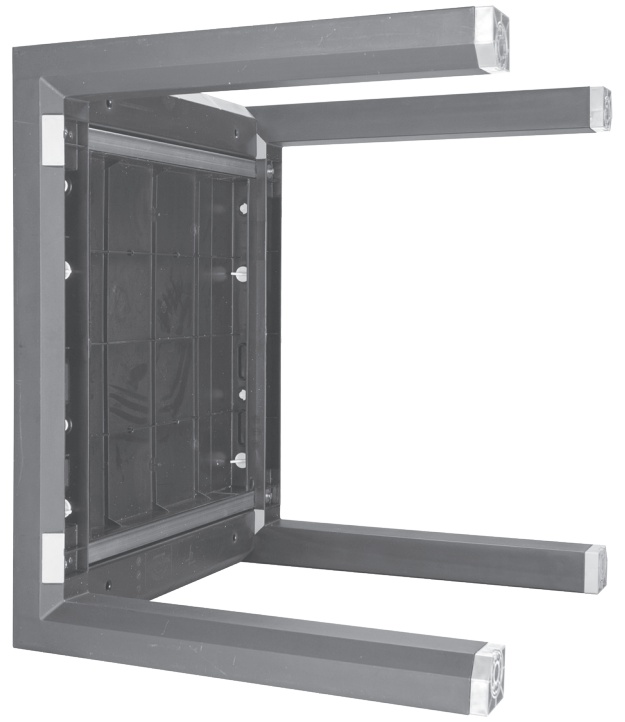

21